

BELL202 Modem Solution Using the Scenix SX Microcontroller

Chris Fogelklou, Scenix Semiconductor, Inc.

Introduction

This document describes the source code [sx_modem_3_51.src](#).

In the past, such telephony functions as FSK (frequency-shift keying) generation and detection, DTMF (dual-tone, multi-frequency) dialing generation and detection, and Caller ID could not be implemented with an 8-bit embedded MCU because performance levels were not high enough to support them. As a result, either a custom MCU had to be designed or a 16- or 32-bit device used. Now, the 8-bit Scenix Semiconductor SX Series MCUs, which have performance reaching 100 MIPS (million instructions per second) and a deterministic interrupt architecture, overcome this roadblock by providing the ability to perform these functions in software.

This document describes the use of a Scenix SX Microcontroller to perform the entire signal generation and detection functions required for a fully functional BELL202 modem. These Virtual Peripherals include:

- DTMF (Dual Tone Multiple Frequency Signalling) generation for dialing.
- FSK (Frequency Shift Keying) generation for transmitting data.
- FSK detection for receiving data.
- UART (Universal Asynchronous Receiver/Transmitter) for RS-232 communications with a PC.
- 16-bit timer for delay routines/flashing LED.

A modem is a tool used to allow digital equipment to communicate using regular telephone lines. Telephone lines are designed to transmit analog signals, and since digital equipment communicate with digital signals a modem's job is to convert the digital signals from the equipment into an analog signal for transmission over a telephone line. On the other end of the line, the receiving modem converts the incoming analog signal back into a digital signal which is then received by the receiving equipment.



BELL202 Modem Solution Using the Scenix SX Microcontroller

Chris Fogelklou, Scenix Semiconductor, Inc.

Converting a digital signal into an analog one requires some form of MODULATION.

MODULATION is the process of converting one form of signal into another. One of the first modulation schemes used for data transmission over telephone lines was Frequency Shift Keying (FSK.) FSK uses frequency- shifts to transmit data. Since binary data is stored as '1's and '0's, there are two frequencies used for Frequency Shift Keying; one frequency symbolizes high data, and the other frequency symbolizes low data. When a bitstream is being transmitted, the transmitting modem outputs a continuous sine wave, with the frequency of the sine wave alternating as the data bits are modulated. The SX modem uses a frequency of 1300Hz to signify a '1' and 2100Hz to signify a '0'. Some applications of Frequency Shift Keying signals include credit card readers, ATM machines, remote monitoring equipment, and Caller ID detection.

The SX Modem also requires some method of dialing. Since DTMF is the most common method of dialing in North America, it was incorporated into the modem. DTMF (touch-tone) stands for Dual-Tone Multi-Frequency signalling. DTMF uses two separate frequencies to indicate the digit to dial. Since two tones are required to dial, there is a much smaller chance that the frequencies will occur during a normal telephone conversation. In order to generate DTMF, the SX is required to create an analog signal consisting of two separate frequencies. This is accomplished by using two Artificial Sine Wave VP's, in conjunction with a PWM (Pulse-Width-Modulated) Digital-to-Analog conversion VP.



BELL202 Modem Solution Using the Scenix SX Microcontroller

Chris Fogelklou, Scenix Semiconductor, Inc.

Introduction...

Unlike other MCUs that add functions in the form of additional silicon, the SX Series uses its industry-leading performance to execute functions as software modules, or Virtual Peripherals. These are loaded into a high-speed (10 ns access time) on-chip flash/EEPROM program memory and executed as required. In addition, a set of on-chip hardware peripherals is available to perform operations that cannot readily be done in software, such as timers, comparators, and oscillators.

To minimize code space and required processing power, the SX modem uses two artificial sine generation VP's and one PWM output to generate both FSK and DTMF signals. With all subroutines and Virtual Peripherals integrated, the Scenix FSK modem solution is less than 900 words long, leaving 1.1K of program memory left over to add such features as CallerID parsing, ring detection, error detection/correction, and an AT-command set.

The Hardware: Block Diagram

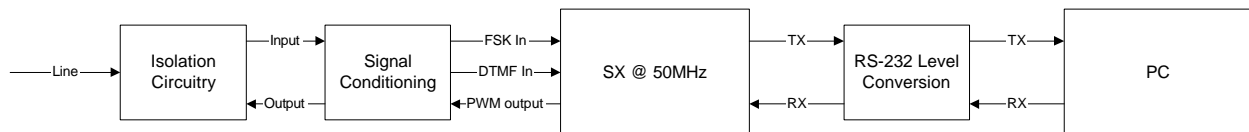

Isolation Circuitry:

Isolation circuitry is needed for any circuit meant to interface with a telephone line. There is a different isolation standard for every country so check which one is used locally.



BELL202 Modem Solution Using the Scenix SX Microcontroller

Chris Fogelklou, Scenix Semiconductor, Inc.

Signal Conditioning:

FSK Input:

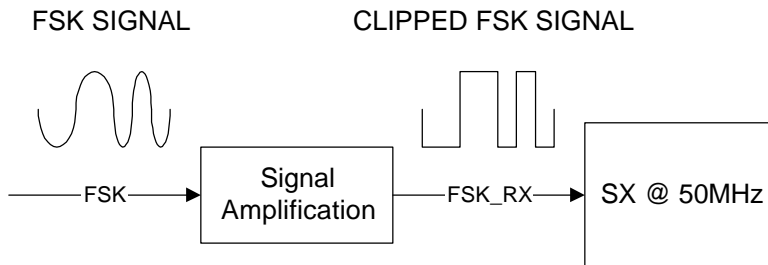

The software implementation of FSK detection is very simple. The transitions on the input pin are timed by the software. If the transitions occur within a specified time, then a high frequency is being detected, otherwise a low frequency is being detected

Since the software uses a Schmitt Trigger input on the SX, the input FSK signal must be amplified until clipping to trigger the Schmitt Trigger levels.

FSK/DTMF Output:

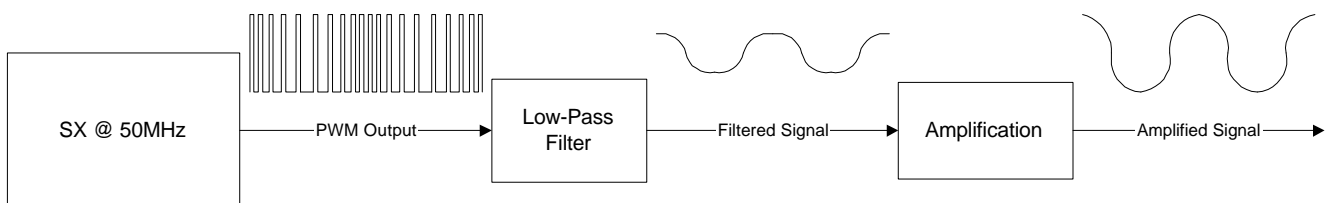

To convert the internal digital values inside the SX back into real-world analogue signals, a Digital-to-Analogue converter (D/A) is required. The SX modem uses a single 8-bit PWM virtual peripheral to accomplish the conversion. A PWM register is loaded with a value from 0 to 255, and this value represents the duty cycle of the PWM output. For DTMF generation, the PWM register is loaded with the sum of the amplitudes of each of the sine waves representing the digit.



BELL202 Modem Solution Using the Scenix SX Microcontroller

Chris Fogelklou, Scenix Semiconductor, Inc.

Signal Conditioning:

Low-Pass Filter:

The low-pass filter used to create the output signal can be as simple as an R-C network.

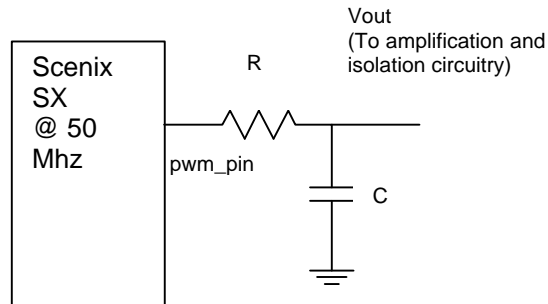

Depending on the maximum frequency you wish to obtain, you should adjust the component values for R and C to choose the resolution of the PWM. Ideally, you should calculate the maximum SIN frequency output you will use and choose the cutoff to be at this frequency. Since the maximum frequency used by the modem software is 2.1kHz, calculate R and C:

First, choose a value for R.

R=1000 ohms

Now, calculate C:

$$C = 1/(2 * \pi * \text{Cutoff Frequency} * R)$$

Therefore:

$$C = 1/(2 * 3.14 * 2100\text{Hz} * 1000 \text{ ohms})$$

And

$$C = 0.076\mu\text{F}$$

The pins used by the SX Modem are:

rx_pin	equ	ra.1	; RS-232 input pin
fsk_in	equ	rb.1	; FSK input pin
PWM_pin	equ	ra.0	; PWM output for D/A
tx_pin	equ	ra.2	; RS-232 output pin
in_out	equ	ra.3	; Enables/Disables output ; on SX DTMF DEMO boards.
led_pin	equ	rb.0	; LED output pin
hook	equ	rb.4	; Selects on-hook/off-hook



BELL202 Modem Solution Using the Scenix SX Microcontroller

Chris Fogelklou, Scenix Semiconductor, Inc.

The Software

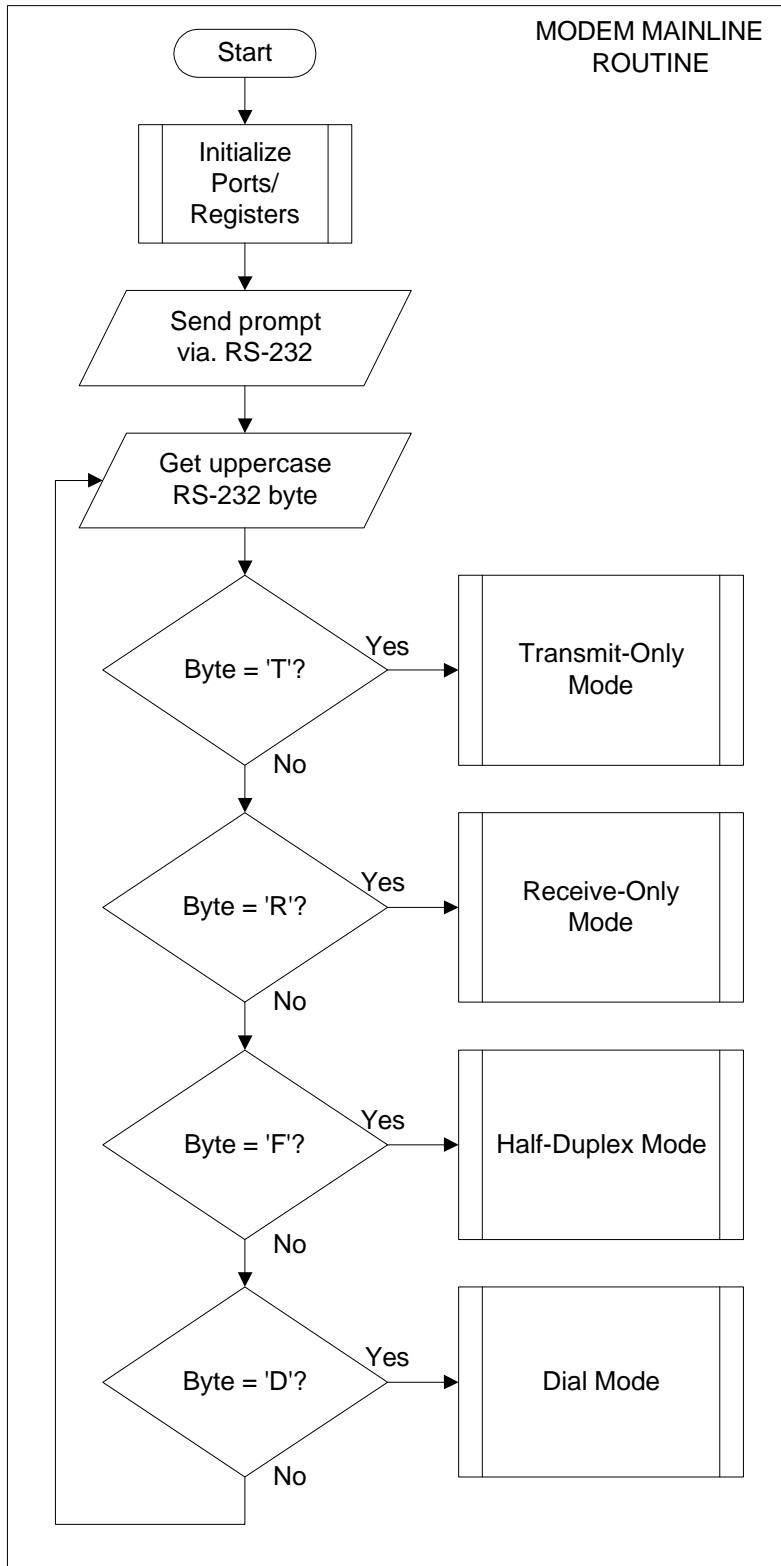

The software consists of an interrupt service routine and a mainline routine. The two routines run independently, with the interrupt service routine running all of the timing sensitive portions of the program, such as the UARTs, timers, A/Ds, D/As, frequency generation, and frequency detection. The mainline routine coordinates, enables, and disables the Virtual Peripherals when necessary to create the overall modem algorithm.

To test this initial release of the modem, a production BELL202 modem was used, in addition to CallerID signals generated by the Telephone Company.



BELL202 Modem Solution Using the Scenix SX Microcontroller

Chris Fogelklou, Scenix Semiconductor, Inc.

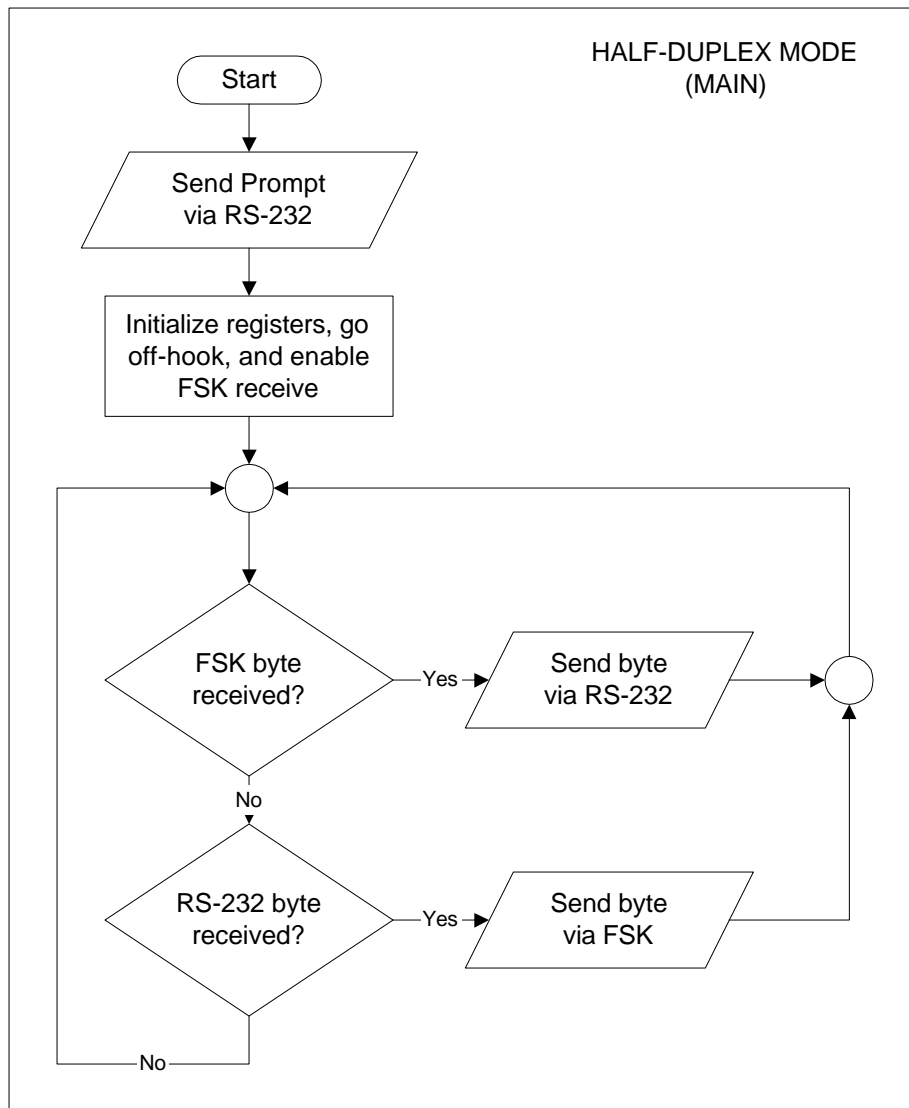

BELL202 Modem Solution Using the Scenix SX Microcontroller

Chris Fogelklou, Scenix Semiconductor, Inc.

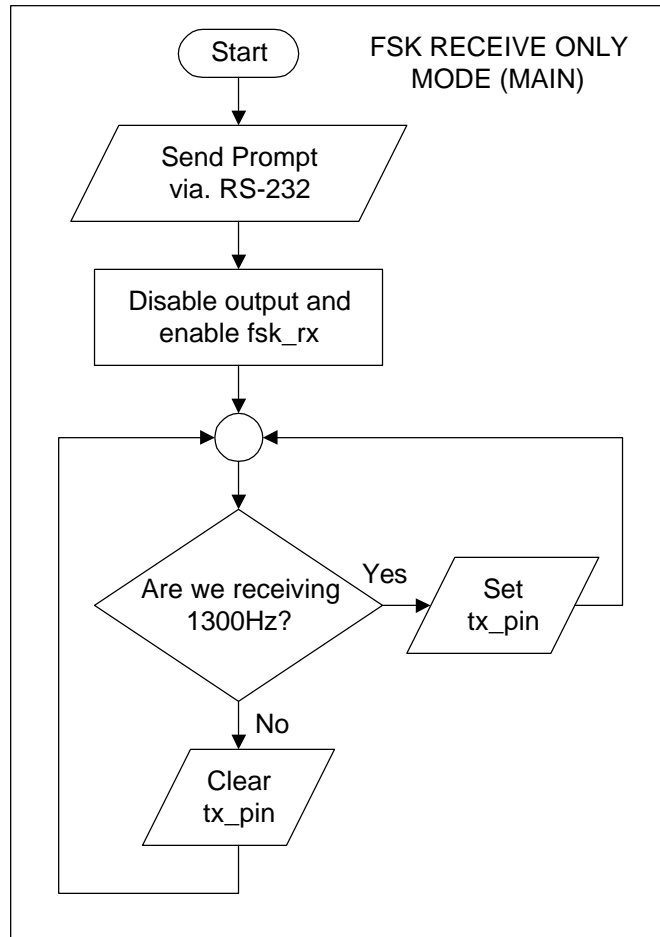

BELL202 Modem Solution Using the Scenix SX Microcontroller

Chris Fogelklou, Scenix Semiconductor, Inc.

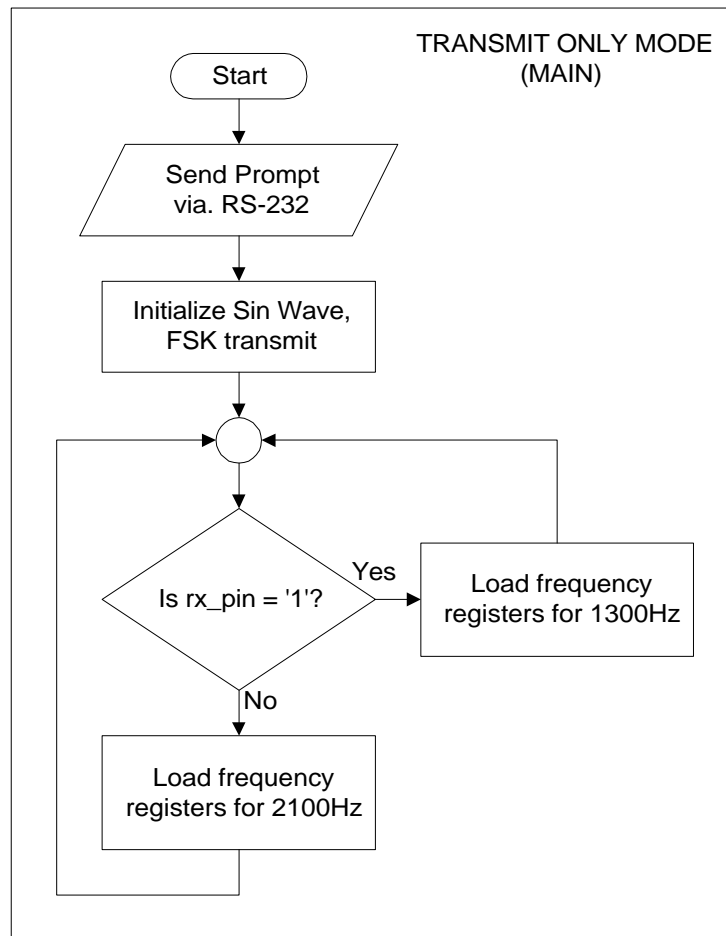

BELL202 Modem Solution Using the Scenix SX Microcontroller

Chris Fogelklou, Scenix Semiconductor, Inc.

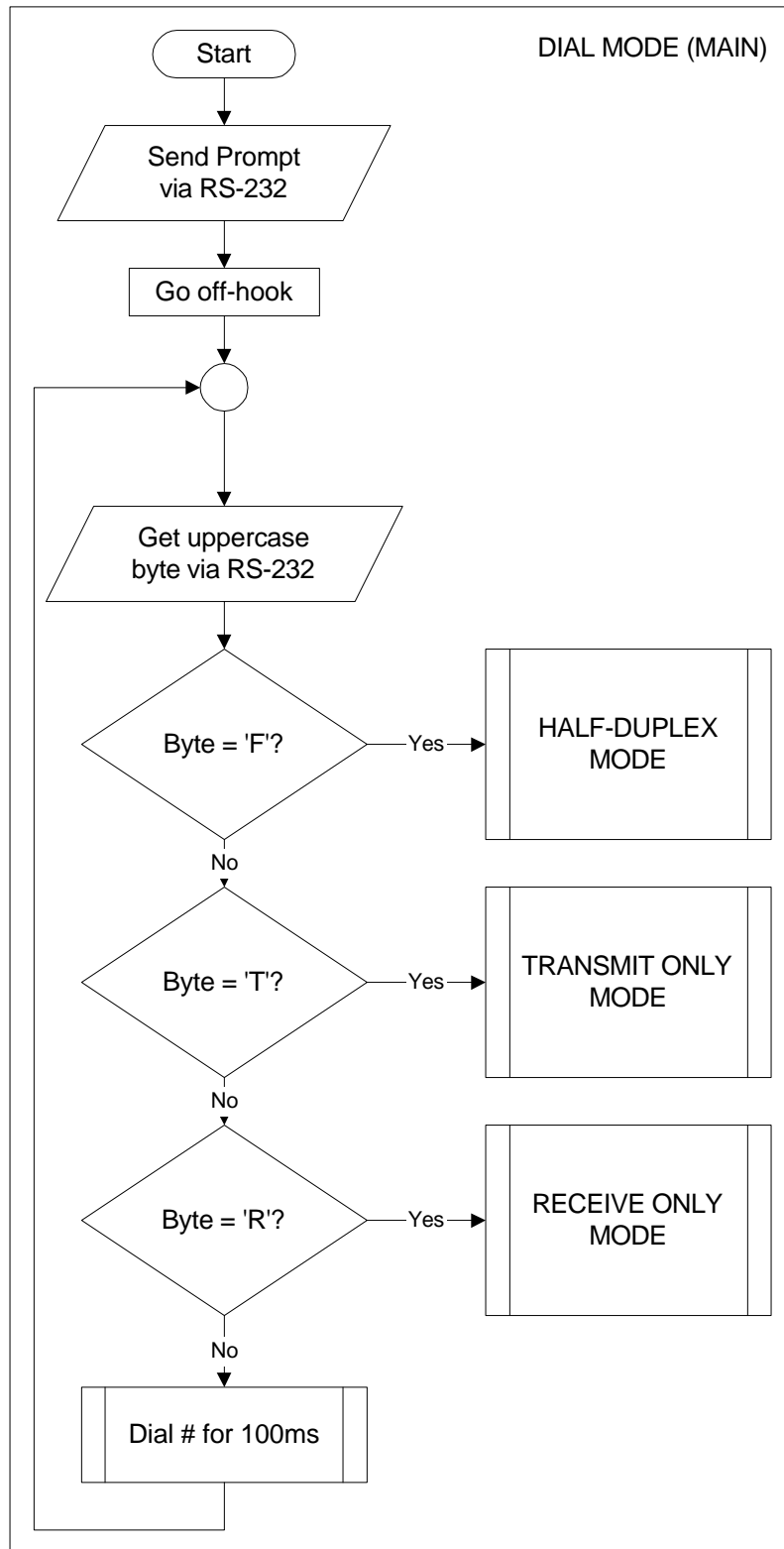

BELL202 Modem Solution Using the Scenix SX Microcontroller

Chris Fogelklou, Scenix Semiconductor, Inc.

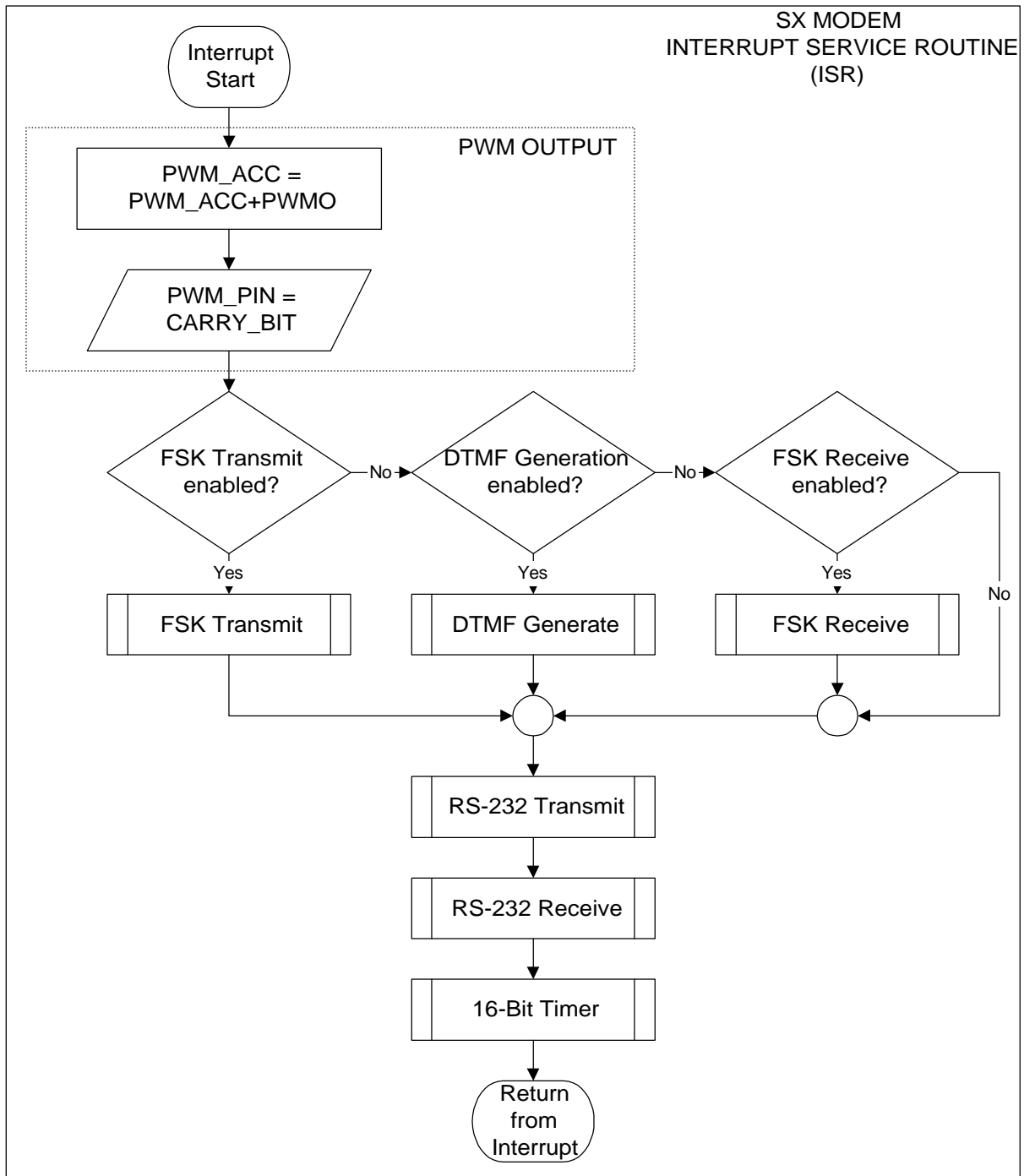

BELL202 Modem Solution Using the Scenix SX Microcontroller

Chris Fogelklou, Scenix Semiconductor, Inc.

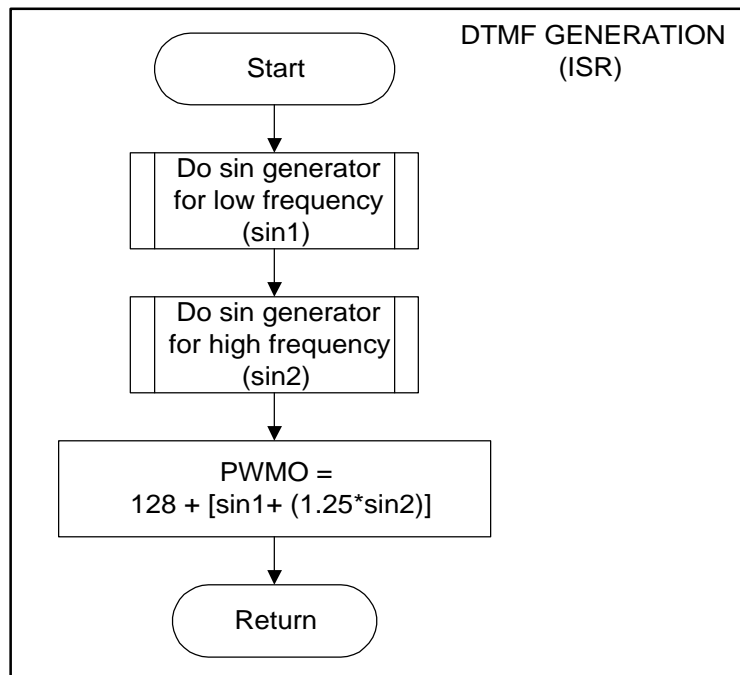
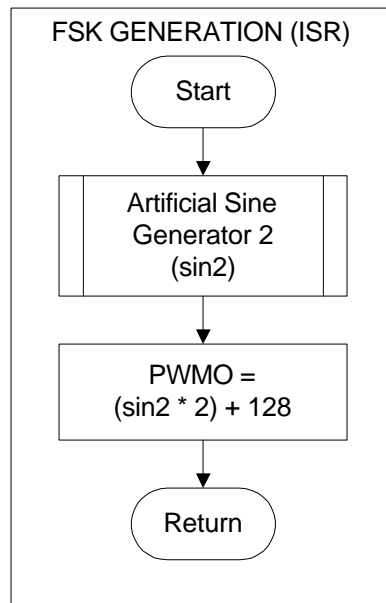

BELL202 Modem Solution Using the Scenix SX Microcontroller

Chris Fogelklou, Scenix Semiconductor, Inc.

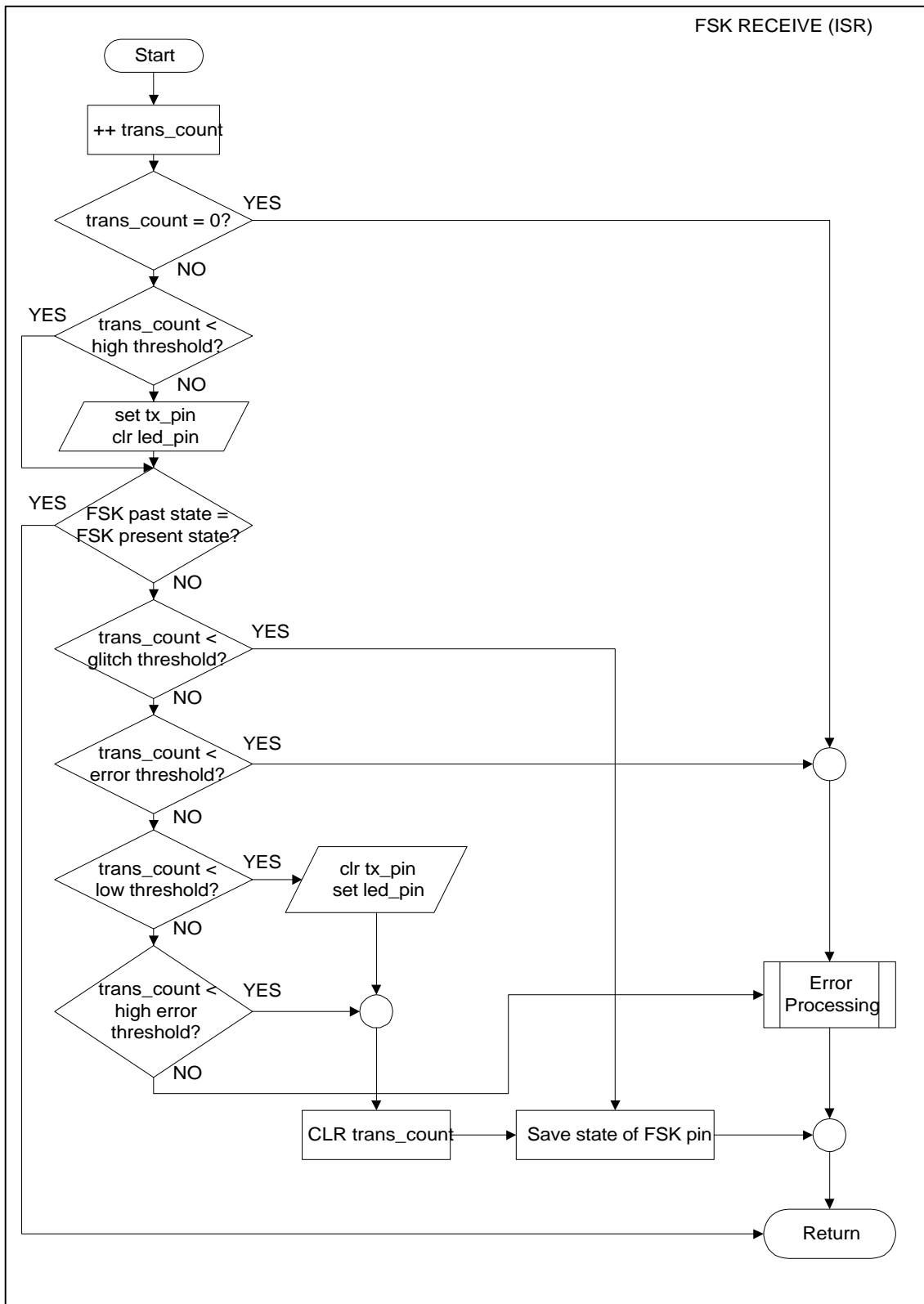

BELL202 Modem Solution Using the Scenix SX Microcontroller

Chris Fogelklou, Scenix Semiconductor, Inc.

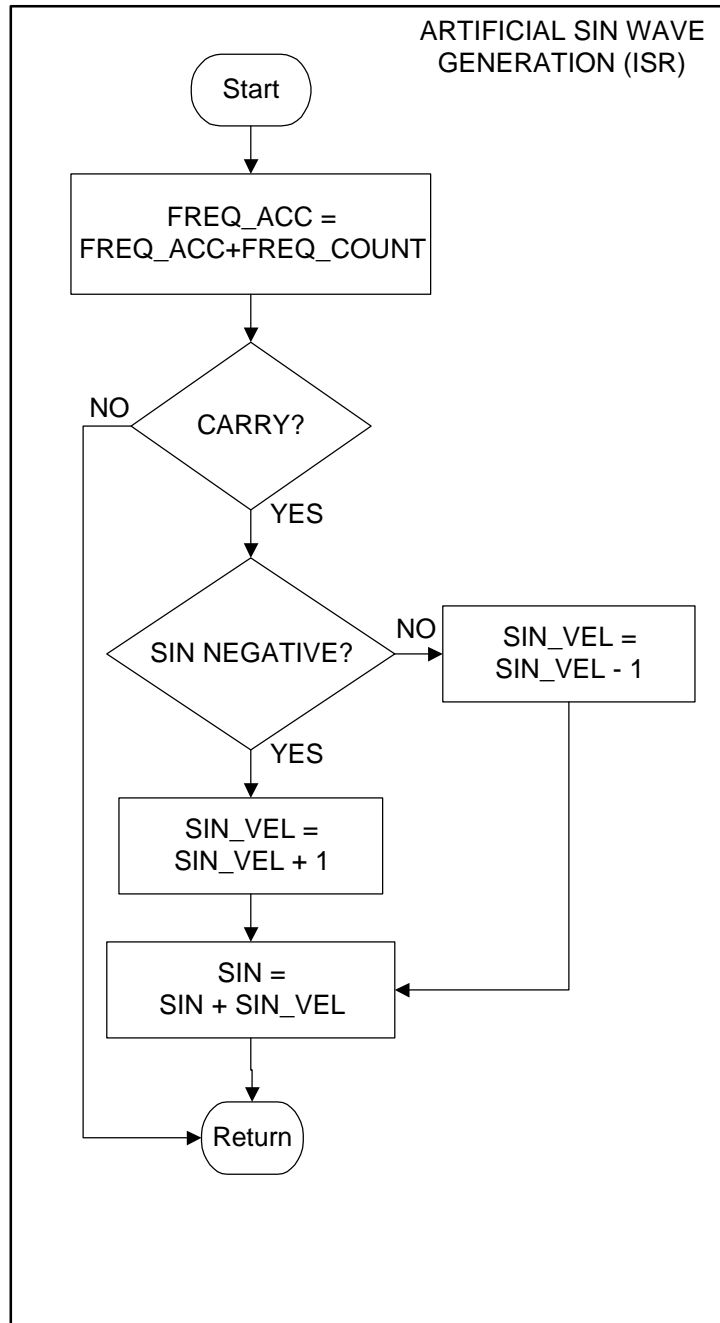

BELL202 Modem Solution Using the Scenix SX Microcontroller

Chris Fogelklou, Scenix Semiconductor, Inc.

Modem Schematic

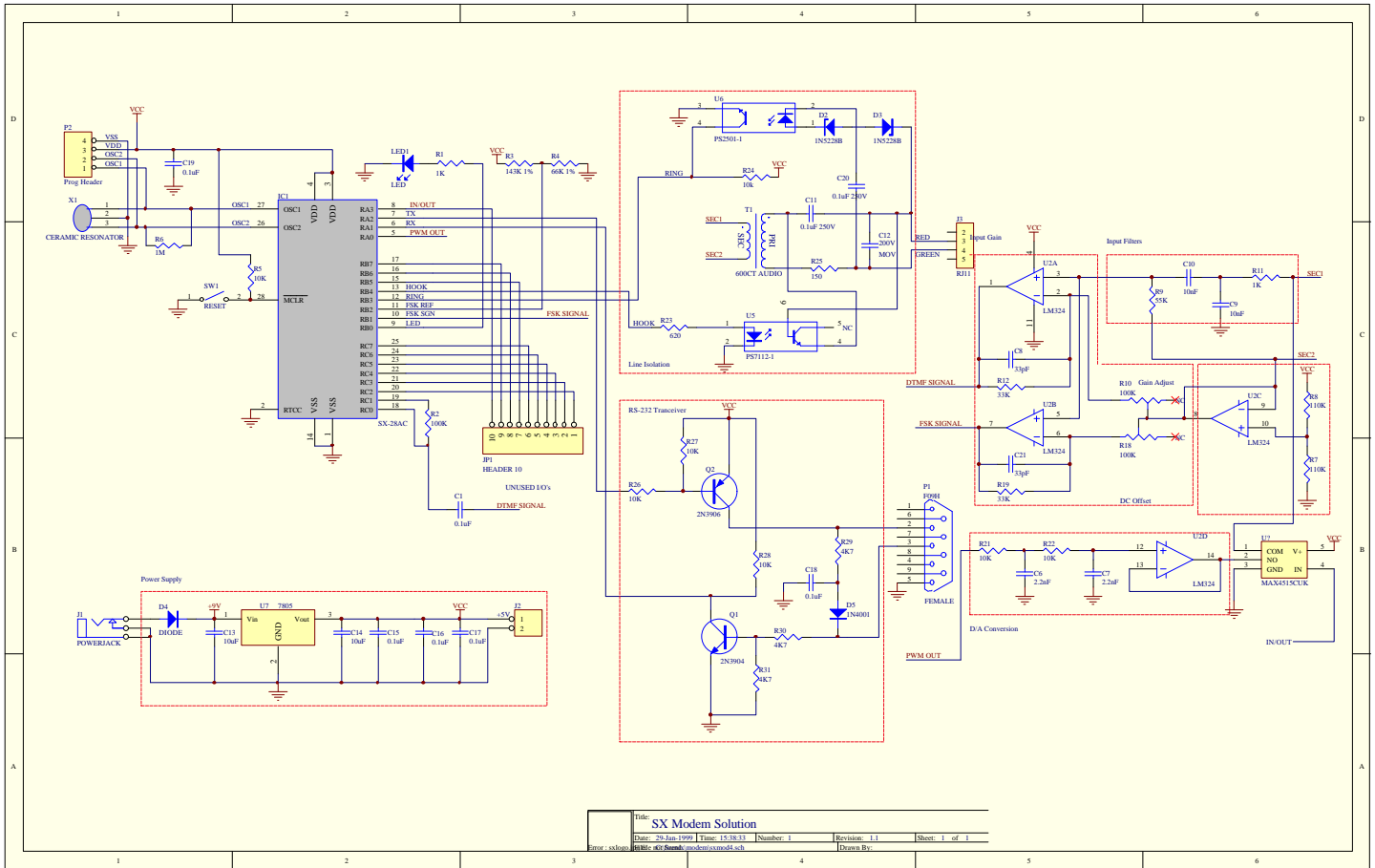

This schematic shows the latest revision of the hardware. Since the design of this board, we have found that much of the hardware is unnecessary, such as the potentiometers, the analog switch, the comparator reference resistors, and, quite possibly, the op-amp. Keep in touch with www.scenix.com for any updates we make available.

